

Technical Manual

JBL JRX125

SPECIFICATIONS



ACOUSTIC & ELECTRICAL SPECIFICATIONS:

- Nominal Impedance: 4 Ohms
- Power Capacity: 500W, Peak Power Capacity 2000W
- Frequency Range: 35 Hz – 16 kHz (-10 dB)
- Sensitivity: 100 dB, 1 Watt @ 1 Meter
- Crossover Frequency: 2 kHz

SYSTEM COMPONENTS:

- Cabinet: Enclosure (Not For Sale)
- Grille: 352934-001
- Low Frequency Transducer: (2) M115-8A, 380mm (15in.) Cone Transducer
- DC Resistance: 5.3 ohms
- High Frequency Transducer: 2412H-1, 25.4mm (1 in.) Exit Compression Driver

SYSTEM COMPONENTS: (CONT'D)

- DC Resistance: 4.3 ohms
- Crossover Network: 364248-001

AURAL SWEEP TEST SPECIFICATIONS:

- A. System Aural Sweep Test: 10.0V Input, 20 Hz to 20 kHz
- B. L.F. Aural Sweep Test: 7.0V Input, 20 Hz to 1.2 kHz
- C. H.F. Aural Sweep Test: 2.83V Input, 500 Hz to 20 kHz

PHYSICAL SPECIFICATIONS:

- Enclosure Dimensions: 1092.2x 463.6 x 431.8mm D (43.0 x 18.25 x 17.0 in.D.)
- Shipping Weight: 103.0 lb (46.7 kg.)

WARRANTY INFORMATION:

- Refer to Warranty Statement packed with each product.

PACKAGE

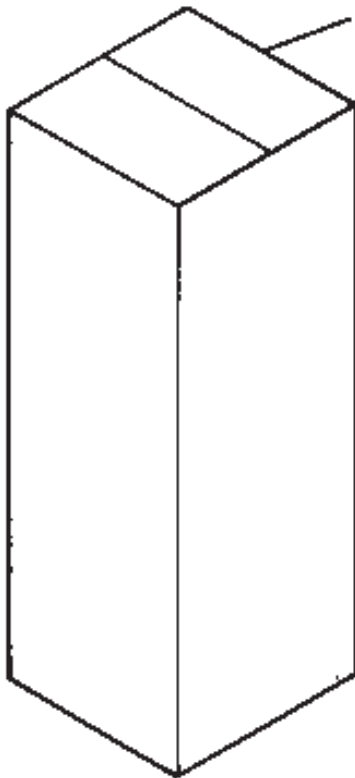

Warranty 59660
Spec Sheet 352931-001

Carton
352930-003

Filler, (2)
339021-001

PKG, Microfoam (4)
49790P
20" x 18" sheets

WIRING DIAGRAM

Low Freq. (2)
M115-8A
(124-67001-01X)

Driver, High Freq
2412H-1
(339013-001X)

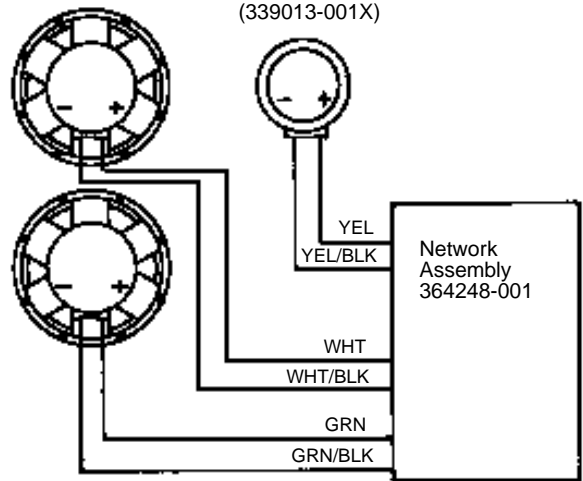

NETWORK SCHEMATIC - (364248-001)

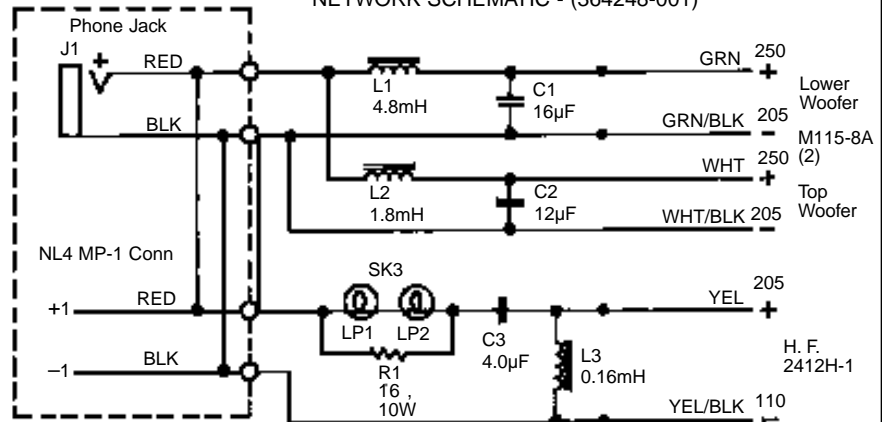

JBL JRX125

COMPONENT EXPLODED VIEW

